



Silenziatore in bronzo sinterizzato alto tronco conico fil. G 3/8" M



DATI TECNICI

Pressione max. esercizio

10 bar

Temperatura ambiente

-10 ÷ 85 °C

Avvertenze Tecniche

DIMENSIONI

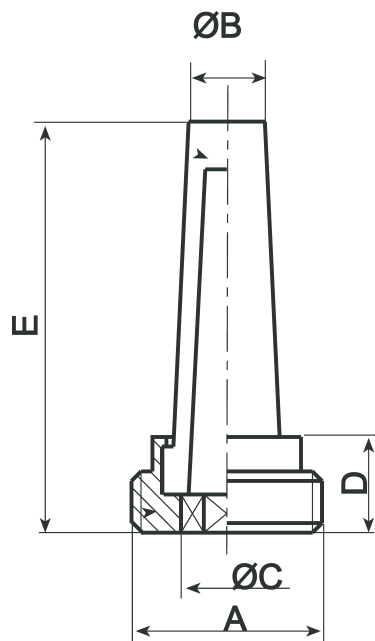

A	B	D	E	F
G 3/8"	7,5	8	36	9,3



Materiali

Bronzo sinterizzato

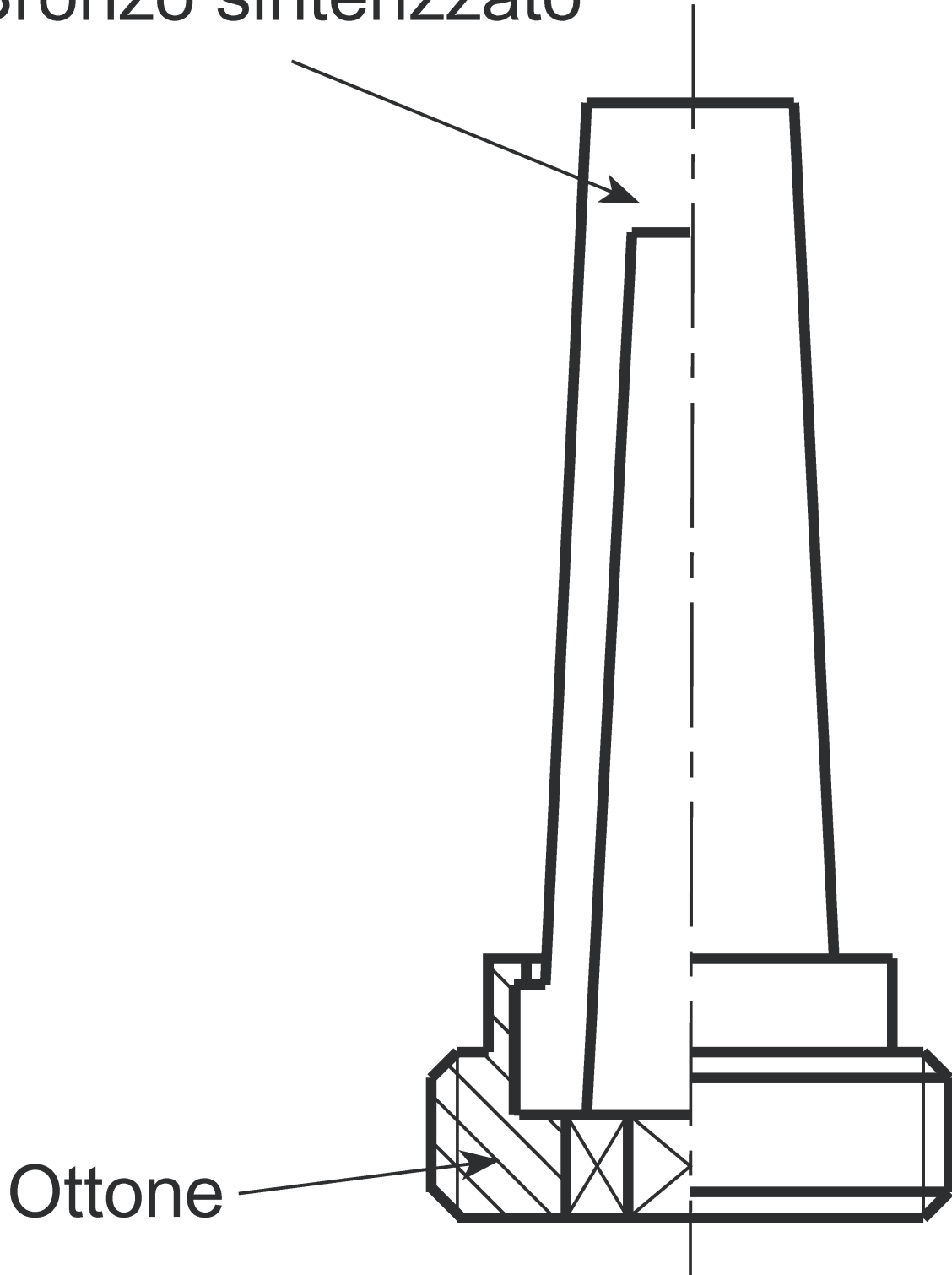

Originale: 3163x4207 px (267.8x356.2 mm) | Mostrata: 154.1x205.0 mm | Ridimensionata: Sì