



Silenziatore in bronzo sinterizzato fil. G 3/8" M



DATI TECNICI

Pressione max. esercizio

10 bar

Temperatura ambiente

-10 ÷ 85 °C

Avvertenze Tecniche

DIMENSIONI

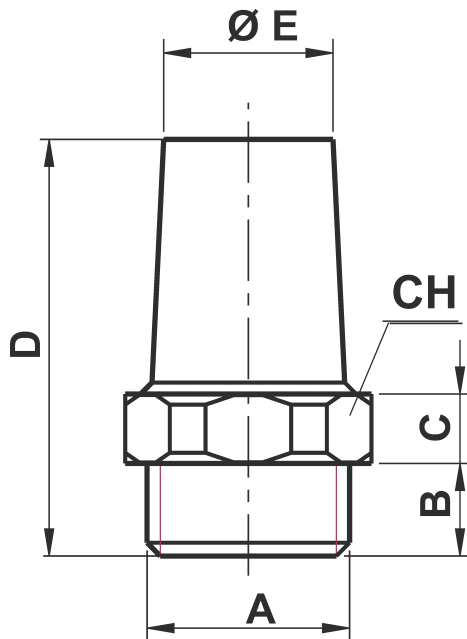

A	B	C	D	E	CH
G 3/8"	7	5.4	35	20	19



Materiali

Bronzo
sinterizzato

Ottone

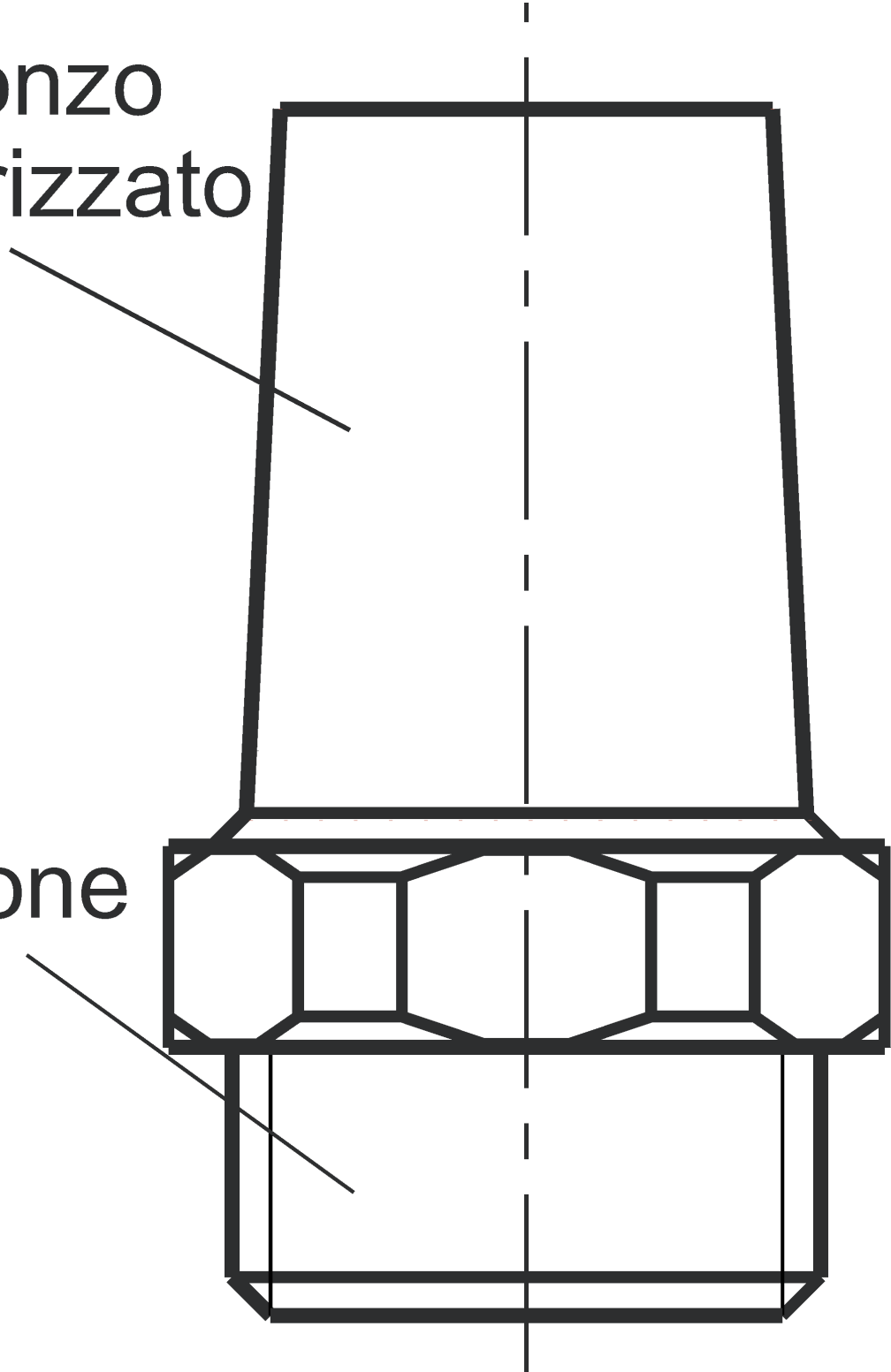

Originale: 2505×3085 px (212.1×261.2 mm) | Mostrata: 166.5×205.0 mm | Ridimensionata: Sì